



NC DEPARTMENT OF
**HEALTH AND
HUMAN SERVICES**

ROY COOPER • Governor

MANDY COHEN, MD, MPH • Secretary

MARK PAYNE • Director, Division of Health Service Regulation

July 25, 2019

John Green
557 Brookdale Drive
Statesville, NC 28677

Exempt from Review

Record #: 2992
Facility Name: Iredell Memorial Hospital, Incorporated
FID #: 933284
Business Name: Iredell Memorial Hospital, Incorporated
Business #: 1032
Project Description: Modernize endoscopy suite
County: Iredell

Dear Mr. Green:

The Healthcare Planning and Certificate of Need Section, Division of Health Service Regulation (Agency), determined that based on your letter of **July 16, and July 22, 2019**, the above referenced proposal is exempt from certificate of need review in accordance with N.C. Gen. Stat. §131E-184(g). Therefore, you may proceed to offer, develop or establish the above referenced project without a certificate of need.

However, you need to contact the Agency's Construction and Acute and Home Care Licensure and Certification Sections to determine if they have any requirements for development of the proposed project.

It should be noted that this determination is binding only for the facts represented by you. Consequently, if changes are made in the project or in the facts provided in your correspondence referenced above, a new determination as to whether a certificate of need is required would need to be made by the Agency. Changes in a project include, but are not limited to: (1) increases in the capital cost; (2) acquisition of medical equipment not included in the original cost estimate; (3) modifications in the design of the project; (4) change in location; and (5) any increase in the number of square feet to be constructed.

If you have any questions concerning this matter, please feel free to contact this office.

Sincerely,

Gregory F. Yakaboski
Project Analyst

Martha J. Frisone
Chief

cc: Construction Section, DHSR
Acute and Home Care Licensure and Certification Section, DHSR

NC DEPARTMENT OF HEALTH AND HUMAN SERVICES • DIVISION OF HEALTH SERVICE REGULATION
HEALTHCARE PLANNING AND CERTIFICATE OF NEED SECTION

LOCATION: 809 Ruggles Drive, Edgerton Building, Raleigh, NC 27603
MAILING ADDRESS: 809 Ruggles Drive, 2704 Mail Service Center, Raleigh, NC 27699-2704
www.ncdhhs.gov/dhsr • TEL: 919-855-3873

AN EQUAL OPPORTUNITY / AFFIRMATIVE ACTION EMPLOYER

Yakaboski, Greg

From: Kelly Ivey <kivey@pda-inc.net>
Sent: Tuesday, July 23, 2019 11:03 AM
To: Yakaboski, Greg
Subject: RE: [External] Exemption Request - Iredell Health System
Attachments: Endoscopy CON Exemption - Additional Info 07.18.19 Response.pdf

CAUTION: External email. Do not click links or open attachments unless you verify. Send all suspicious email as an attachment to report.spam@nc.gov

Hi Greg,

Thanks for the time to get this right. See the attachment with our clarifications. Let me know if you need anything further.

Thank you!
Kelly Ivey

From: Yakaboski, Greg [mailto:greg.yakaboski@dhhs.nc.gov]
Sent: Friday, July 19, 2019 5:29 PM
To: Kelly Ivey <kivey@pda-inc.net>
Subject: RE: [External] Exemption Request - Iredell Health System

No problem.

From: Kelly Ivey <kivey@pda-inc.net>
Sent: Friday, July 19, 2019 4:57 PM
To: Yakaboski, Greg <greg.yakaboski@dhhs.nc.gov>
Subject: RE: [External] Exemption Request - Iredell Health System

CAUTION: External email. Do not click links or open attachments unless you verify. Send all suspicious email as an attachment to report.spam@nc.gov

Hey Greg,

Just wanted you to know we didn't forget. Working on tying up the loose ends, then will have to run thru the IHS crowd for signatures and approvals. I expect we will have it to you by Tuesday. Thanks for being flexible and helping us through this!

Kelly Ivey

From: Yakaboski, Greg [mailto:greg.yakaboski@dhhs.nc.gov]
Sent: Wednesday, July 17, 2019 8:01 PM
To: Kelly Ivey <kivey@pda-inc.net>
Subject: RE: [External] Exemption Request - Iredell Health System

Hey Kelly,

Thanks for what you have sent over so far....below is the definition of "main campus" Really need a letter addressing the key components of the definition and tying into what you have already sent over. Any question please feel free to email me tomorrow and you and I can set up a short phone call.

Greg

(14n) "Main campus" means all of the following for the purposes of G.S. 131E-184(f) and (g) only: a. The site of the main building from which a licensed health service facility provides clinical patient services and exercises financial and administrative control over the entire facility, including the buildings and grounds adjacent to that main building. b. Other areas and structures that are not strictly contiguous to the main building but are located within 250 yards of the main building.

From: Kelly Ivey <kivey@pda-inc.net>
Sent: Wednesday, July 17, 2019 5:37 PM
To: Yakaboski, Greg <greg.yakaboski@dhhs.nc.gov>
Subject: RE: [External] Exemption Request - Iredell Health System

CAUTION: External email. Do not click links or open attachments unless you verify. Send all suspicious email as an attachment to report-spam@nc.gov

Greg,

See attached.

Thank you!
Kelly Ivey

From: Yakaboski, Greg [<mailto:greg.yakaboski@dhhs.nc.gov>]
Sent: Wednesday, July 17, 2019 2:15 PM
To: Kelly Ivey <kivey@pda-inc.net>
Subject: RE: [External] Exemption Request - Iredell Health System

Hey Kelly,

Because of the way the statute reads could you provide additional supporting documentation demonstrating that the endoscopy suites proposed to be modernized are located on the "main campus" of Iredell Memorial Hospital as "main campus" is defined in NC GS Section 131E-176(14n).

I appreciate your help with this.

Thanks,
Greg

From: Kelly Ivey <kivey@pda-inc.net>
Sent: Wednesday, July 17, 2019 11:00 AM
To: Yakaboski, Greg <greg.yakaboski@dhhs.nc.gov>
Cc: Flores, Disraeliza <Disraeliza.Flores@dhhs.nc.gov>
Subject: [External] Exemption Request - Iredell Health System

CAUTION: External email. Do not click links or open attachments unless you verify. Send all suspicious email as an attachment to report_spam@nc.gov

Greg,

Attached is an exemption request submitted on behalf of our client, Iredell Health System. Please respond to this email as confirmation of receipt. Let me know if you have any questions or require additional information.

Thanks for your help,
Kelly

Kelly Ivey

PDA, Inc.

919.754.0303

www.pdaconsultants.com

"Take a problem, make it a feature."

CONFIDENTIALITY NOTICE: This message is confidential and intended solely for the use of the person (s) to whom it is addressed. If you are not the person named, or responsible for delivering it to that person, be aware that disclosure, copying, distribution or use of this information is strictly PROHIBITED. If you have received this communication in error, or are uncertain as to its proper handling, please immediately notify the sender, delete this e-mail and destroy any copies in any form immediately.

Email correspondence to and from this address is subject to the North Carolina Public Records Law and may be disclosed to third parties by an authorized State official. Unauthorized disclosure of juvenile, health, legally privileged, or otherwise confidential information, including confidential information relating to an ongoing State procurement effort, is prohibited by law. If you have received this email in error, please notify the sender immediately and delete all records of this email.



July 22, 2019

Ms. Martha Frisone
Chief, Healthcare Planning and Certificate of Need Section
Gregory Yakaboski CON Analyst
Division of Health Service Regulation/ DHSR
809 Ruggles Drive
Raleigh, NC 27603
Martha.Frisone@dhhs.nc.gov

RE: Additional information and clarification for Request for Exemption from CON Review for Modernization of Endoscopy Suite, Iredell Memorial Hospital, Incorporated, Statesville, Iredell County, FID 933284

Dear Ms. Frisone and Mr. Yakaboski

Per your request, Iredell Memorial Hospital, Incorporated ("Iredell Memorial Hospital"), is providing clarification to its request for exemption from CON review dated July 17, 2019.

Iredell Memorial Hospital is located at 557 Brookdale Drive, Statesville, NC 28677. This is the main campus of the hospital as it relates to G.S. 131E-184(g), and as defined by G.S. 131E-176(14n)a. Iredell Memorial Hospital is the main building from which the licensed hospital provides clinical patient services and exercises financial administrative control over the entire hospital facility. The proposed renovation and expansion will occur in the Iredell Memorial Hospital building. Please see the attached diagrams.

As noted on the attached excerpt from its 2019 Hospital License Renewal Application H0164, Iredell Memorial Hospital is licensed for three dedicated endoscopy rooms. At project end, Iredell Memorial Hospital will continue to have only three dedicated endoscopy rooms.

Sincerely,

A handwritten signature in black ink, appearing to read "John Green", written over a white background.

John Green
President & CEO

CC: Project Analyst: Greg Yakaboski, Greg.Yakaboski@dhhs.nc.gov
Support Staff: Disraeliza Flores, Disraeliza.Flores@dhhs.nc.gov

Attachments:

- Exhibit A – Iredell Memorial Hospital Main Campus aerial view, site plan, existing GI endoscopy suite, proposed GI endoscopy modernization
- Exhibit B – Iredell Memorial Hospital 2019 Hospital License Renewal Application excerpt

Exhibit A – Iredell Memorial Hospital Main Campus aerial view, site plan, existing GI endoscopy suite, proposed GI endoscopy modernization



Iredell Memorial Hospital, Incorporated
Brookdale Drive
Piedmont, NC 28677

Hospital Main Campus

Existing GI endoscopy suite / Proposed
GI endoscopy modernization (1st Floor)

Financial and Administrative Control
(1st Floor)

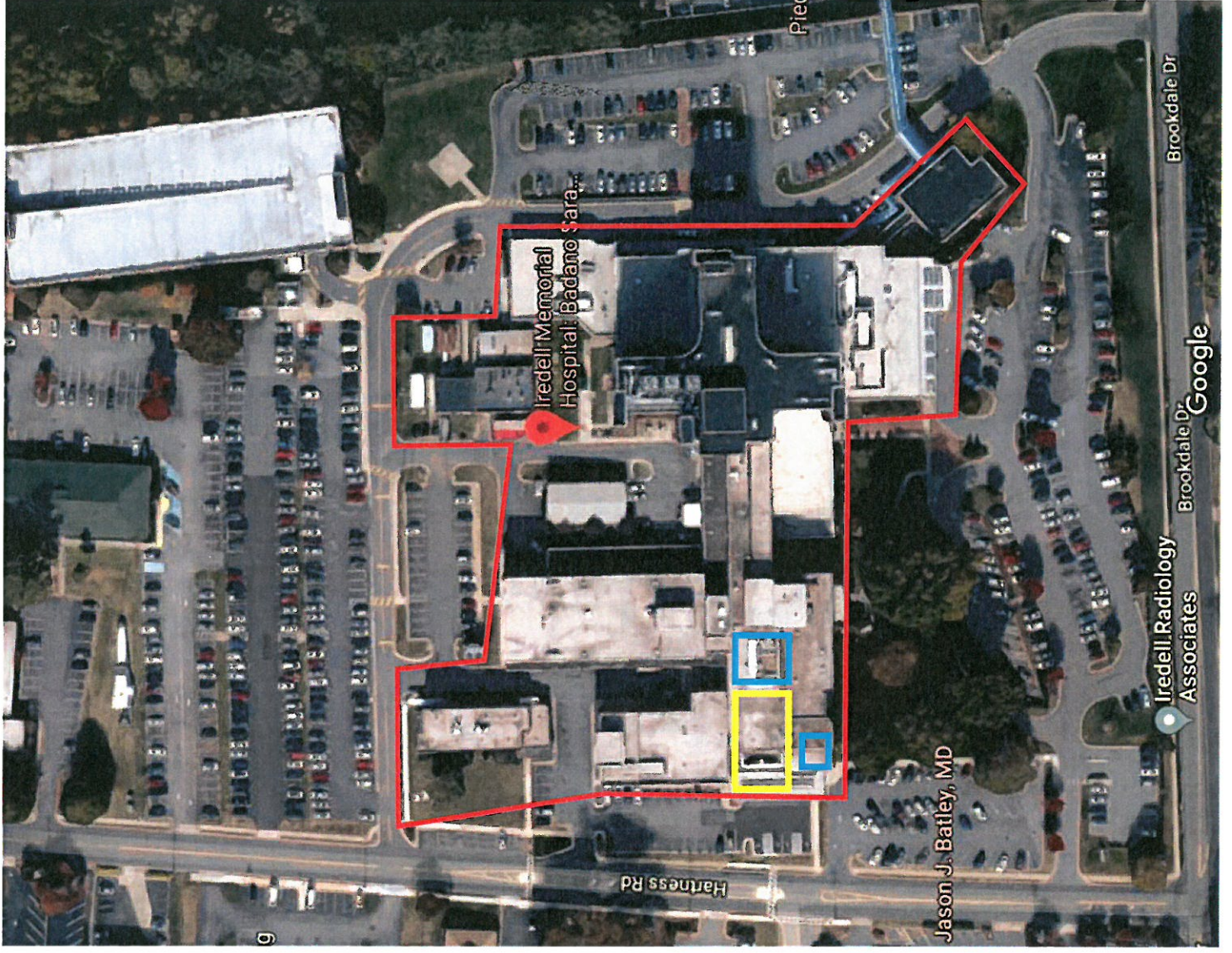

1ST FLOOR
CONSTRUCTION
AREA

CEO OFFICE
(JOHN GREEN)

HOSPITAL
ADMINISTRATION

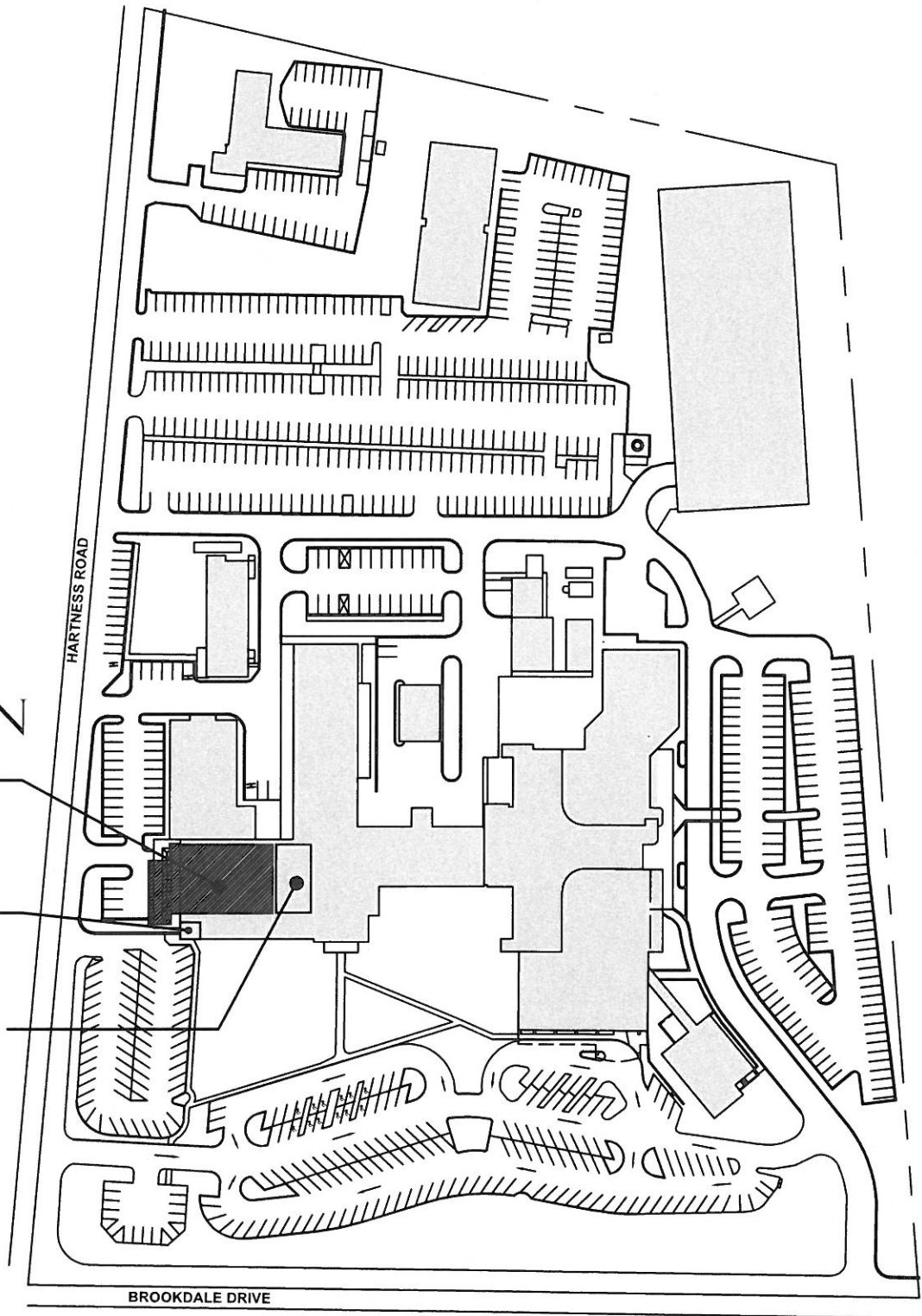

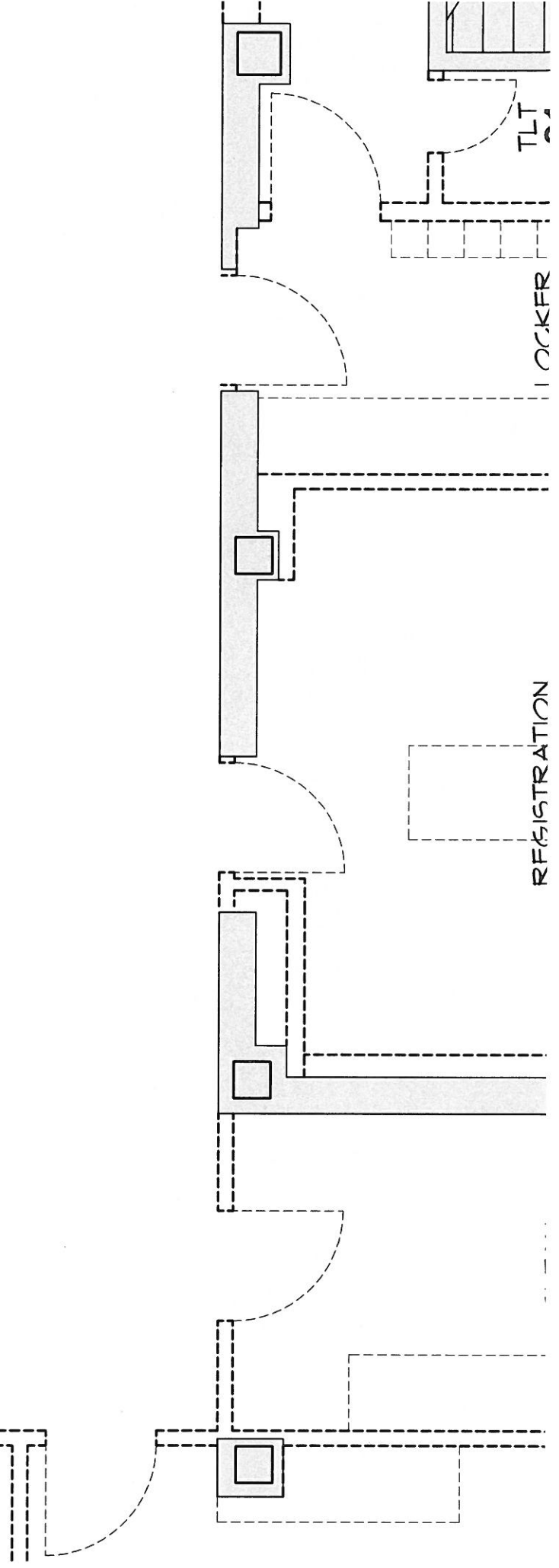
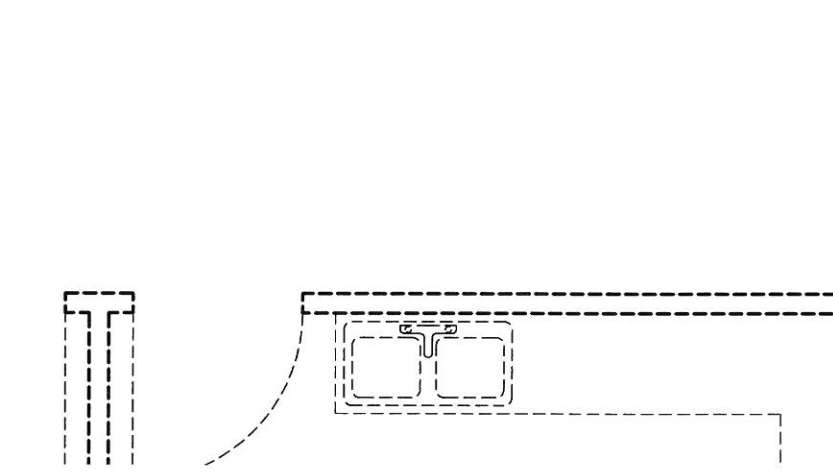
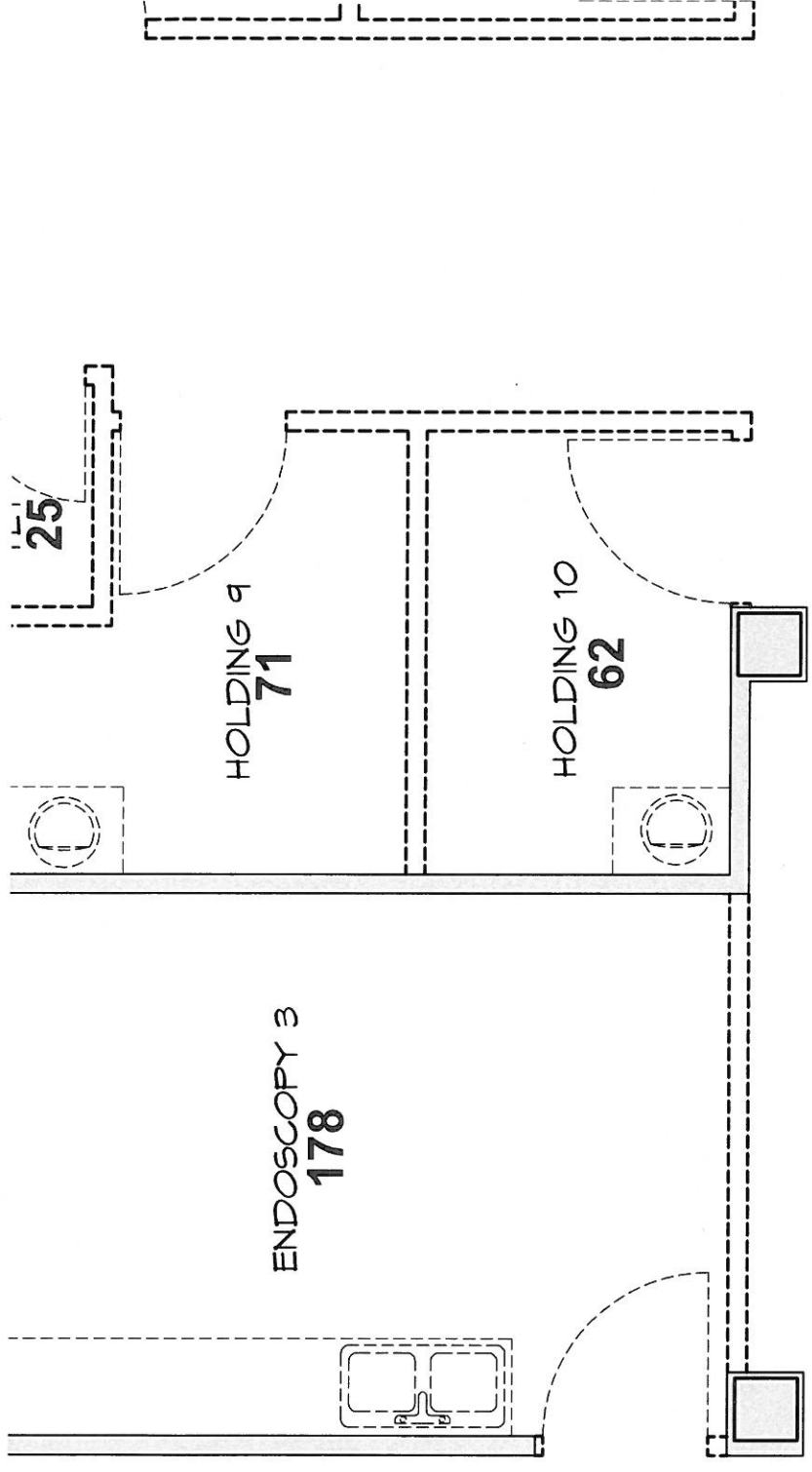

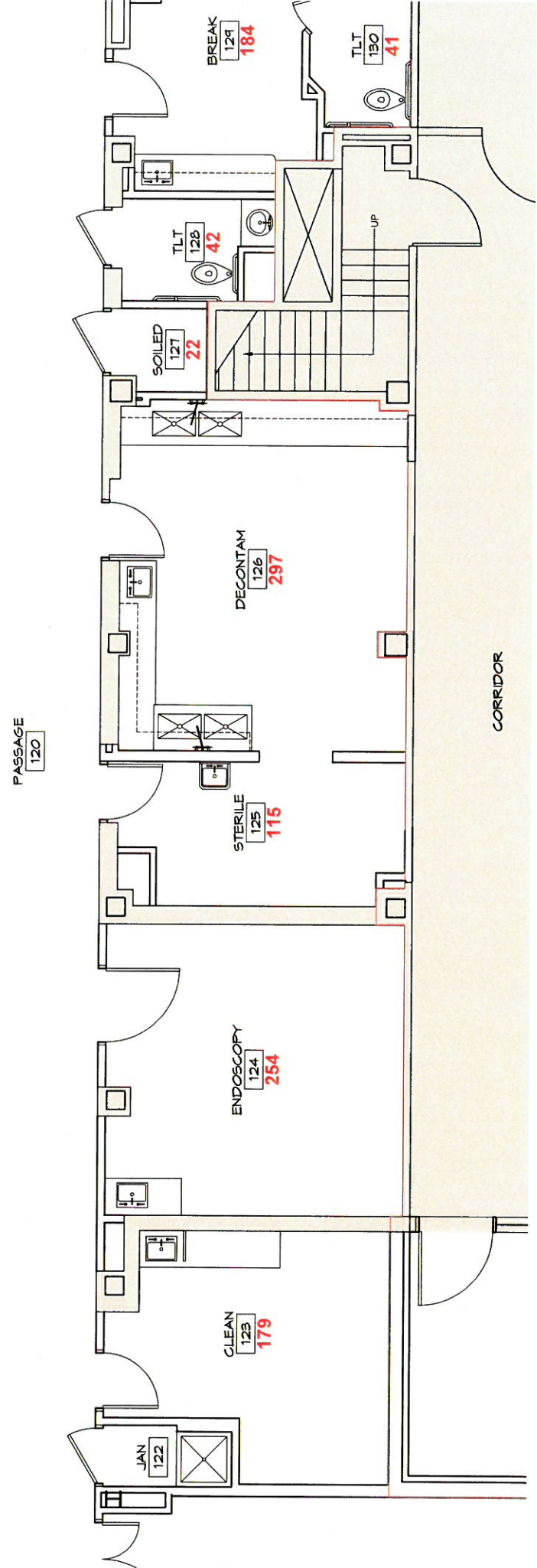
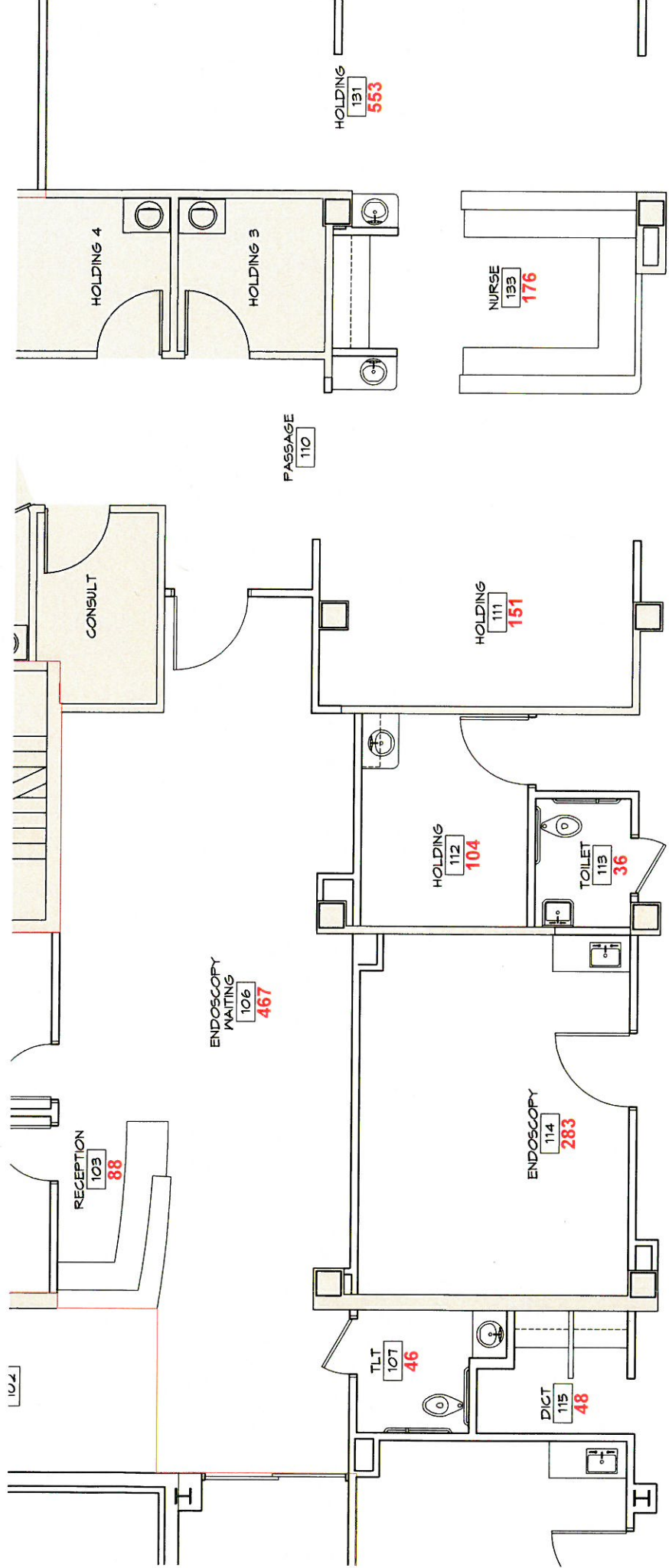

Exhibit B – Iredell Memorial Hospital 2019 Hospital License Renewal Application excerpt

State of North Carolina

Department of Health and Human Services Division of Health Service Regulation

Effective January 01, 2019, this license is issued to

Iredell Memorial Hospital, Incorporated

to operate a hospital known as

Iredell Memorial Hospital, Incorporated

located in Statesville, North Carolina, Iredell County.

*This license is issued subject to the statutes of the
State of North Carolina, is not transferable and shall remain
in effect until amended by the issuing agency.*

Facility ID: 933284

License Number: H0164

Bed Capacity: 247

General Acute 199,

Nursing: 48

Dedicated Inpatient Surgical Operating Rooms: 1

Dedicated Ambulatory Surgical Operating Rooms: 0

Shared Surgical Operating Rooms: 10

Dedicated Endoscopy Rooms: 3

Authorized by:

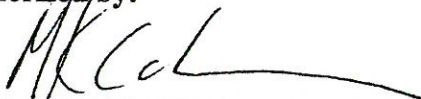

Secretary, N.C. Department of Health and
Human Services

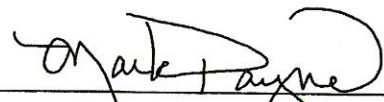
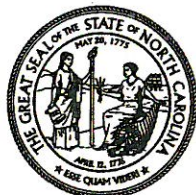

Director, Division of Health Service Regulation

Yakaboski, Greg

From: Kelly Ivey <kivey@pda-inc.net>
Sent: Wednesday, July 17, 2019 5:37 PM
To: Yakaboski, Greg
Subject: RE: [External] Exemption Request - Iredell Health System
Attachments: IMH ENDO NEW & EXISTING AREAS.PDF; IMH Endoscopy Location Plan.pdf

CAUTION: External email. Do not click links or open attachments unless you verify. Send all suspicious email as an attachment to report_spam@nc.gov

Greg,

See attached.

Thank you!
Kelly Ivey

From: Yakaboski, Greg [mailto:greg.yakaboski@dhhs.nc.gov]
Sent: Wednesday, July 17, 2019 2:15 PM
To: Kelly Ivey <kivey@pda-inc.net>
Subject: RE: [External] Exemption Request - Iredell Health System

Hey Kelly,

Because of the way the statute reads could you provide additional supporting documentation demonstrating that the endoscopy suites proposed to be modernized are located on the “main campus” of Iredell Memorial Hospital as “main campus” is defined in NC GS Section 131E-176(14n).

I appreciate your help with this.

Thanks,
Greg

From: Kelly Ivey <kivey@pda-inc.net>
Sent: Wednesday, July 17, 2019 11:00 AM
To: Yakaboski, Greg <greg.yakaboski@dhhs.nc.gov>
Cc: Flores, Disraeliza <Disraeliza.Flores@dhhs.nc.gov>
Subject: [External] Exemption Request - Iredell Health System

CAUTION: External email. Do not click links or open attachments unless you verify. Send all suspicious email as an attachment to report_spam@nc.gov

Greg,

Attached is an exemption request submitted on behalf of our client, Iredell Health System. Please respond to this email as confirmation of receipt. Let me know if you have any questions or require additional information.

Thanks for your help,

Kelly

Kelly Ivey

PDA, Inc.

919.754.0303

www.pdaconsultants.com

"Take a problem, make it a feature."

CONFIDENTIALITY NOTICE: This message is confidential and intended solely for the use of the person (s) to whom it is addressed. If you are not the person named, or responsible for delivering it to that person, be aware that disclosure, copying, distribution or use of this information is strictly PROHIBITED. If you have received this communication in error, or are uncertain as to its proper handling, please immediately notify the sender, delete this e-mail and destroy any copies in any form immediately.

Email correspondence to and from this address is subject to the North Carolina Public Records Law and may be disclosed to third parties by an authorized State official. Unauthorized disclosure of juvenile, health, legally privileged, or otherwise confidential information, including confidential information relating to an ongoing State procurement effort, is prohibited by law. If you have received this email in error, please notify the sender immediately and delete all records of this email.



July 16, 2019

Ms. Martha Frisone
Chief, Healthcare Planning and Certificate of Need Section
Gregory Yakaboski CON Analyst
Division of Health Service Regulation/ DHSR
809 Ruggles Drive
Raleigh, NC 27603
Martha.Frisone@dhhs.nc.gov

RE: Request for Exemption from CON Review for Modernization of Endoscopy Suite, Iredell Memorial Hospital, Incorporated, Statesville, Iredell County, FID 933284

Dear Ms. Frisone and Mr. Yakaboski

The purpose of this letter is to provide notice to the North Carolina Department of Health and Human Services, Division of Health Service Regulation ("DHSR"), Certificate of Need Section (the "CON Section") that Iredell Memorial Hospital Incorporated intends to modernize its endoscopy suite. The project involves capital investment on the main campus of the hospital, License No H0164. The investment will exceed \$2.0 million and will be accomplished over approximately 15 months, during which time, the hospital will continue to provide endoscopy procedures within the area and / or in its operating rooms. During the construction, the hospital also intends to add a procedure room that will not meet the GS 131E-176(7d) definition of Gastrointestinal endoscopy room.

(7d) "Gastrointestinal endoscopy room" means a room used for the performance of procedures that require the insertion of a flexible endoscope into a gastrointestinal orifice to visualize the gastrointestinal lining and adjacent organs for diagnostic or therapeutic purposes.

Nor will the additional procedure room be used for GI endoscopy procedures. At the end of the project, Iredell Memorial Hospital will have three Gastrointestinal endoscopy rooms on its main campus.

The estimated total capital cost of the project, according to our Engineering Department, is between \$4.5 and \$5.5 million, largely because the project involves extending the exterior wall of a building built in 1954. No item of equipment involved in the completed project will cost more than \$750,000. Hence none would qualify as Major Medical Equipment under GS 131E-176 (14o).

(14o) "Major medical equipment" means a single unit or single system of components with related functions which is used to provide medical and other health services and which costs more than seven hundred fifty thousand dollars (\$750,000). In determining whether the major medical equipment costs more than seven hundred fifty thousand dollars (\$750,000), the costs of the equipment, studies, surveys, designs, plans, working drawings, specifications, construction, installation, and other activities essential to acquiring and making operational the major medical equipment shall be included. The capital expenditure for the equipment shall be deemed to be the fair market value of the equipment or the cost of the equipment, whichever is greater. Major medical equipment does not include replacement equipment as defined in this section.

The project is necessary to provide larger endoscopy rooms, and to bring HVAC systems to a more current standard, and to improve workflow and efficiency for our medical and other professional staff as they continue to meet the needs of our population.

We are requesting that the Agency confirm that this change is not reviewable as a new institutional health service under the North Carolina Certificate of Need ("CON") law and exempt from review under the CON law's exemption provisions in N.C. Gen. Stat. § 131E-184(g).

We have included supporting documentation as required:

Sincerely,



John Green
President & CEO

CC: Project Analyst: Greg Yakaboski, Greg.Yakaboski@dhhs.nc.gov
Support Staff: Disraeliza Flores, Disraeliza.Flores@dhhs.nc.gov

Attachments:

Exhibit A - Proposed Total Capital Cost of Project

Projected Capital Cost Form IMH GI Endoscopy

Building Purchase Price	0
Purchase Price of Land	0
Closing Costs	0
Site Preparation	\$90,000
Construction/Renovation Contract(s)	\$3,900,000
Landscaping	0
Architect / Engineering Fees	\$300,000
Medical Equipment	\$900,000
Non-Medical Equipment	\$100,000
Furniture	\$50,000
Consultant Fees (specify)	0
Financing Costs	N/A
Interest during Construction	N/A
Other (specify)	N/A
Total Capital Cost	\$5,340,000

CERTIFICATION BY A LICENSED ARCHITECT OR ENGINEER

I certify that, to the best of my knowledge, the projected capital cost for the proposed project is complete and correct.



Signature of Licensed Architect or Engineer

Date Signed: 7/16/19

CERTIFICATION BY AN OFFICER OR AGENT FOR THE PROPONENT

I certify that, to the best of my knowledge, the projected total capital cost for the proposed project is complete and correct and that it is our intent to carry out the proposed project as described.



Signature of Officer/Agent: John Green,

Date Signed: 7/16/19

President & CEO John G. Green
Title of Officer/Agent

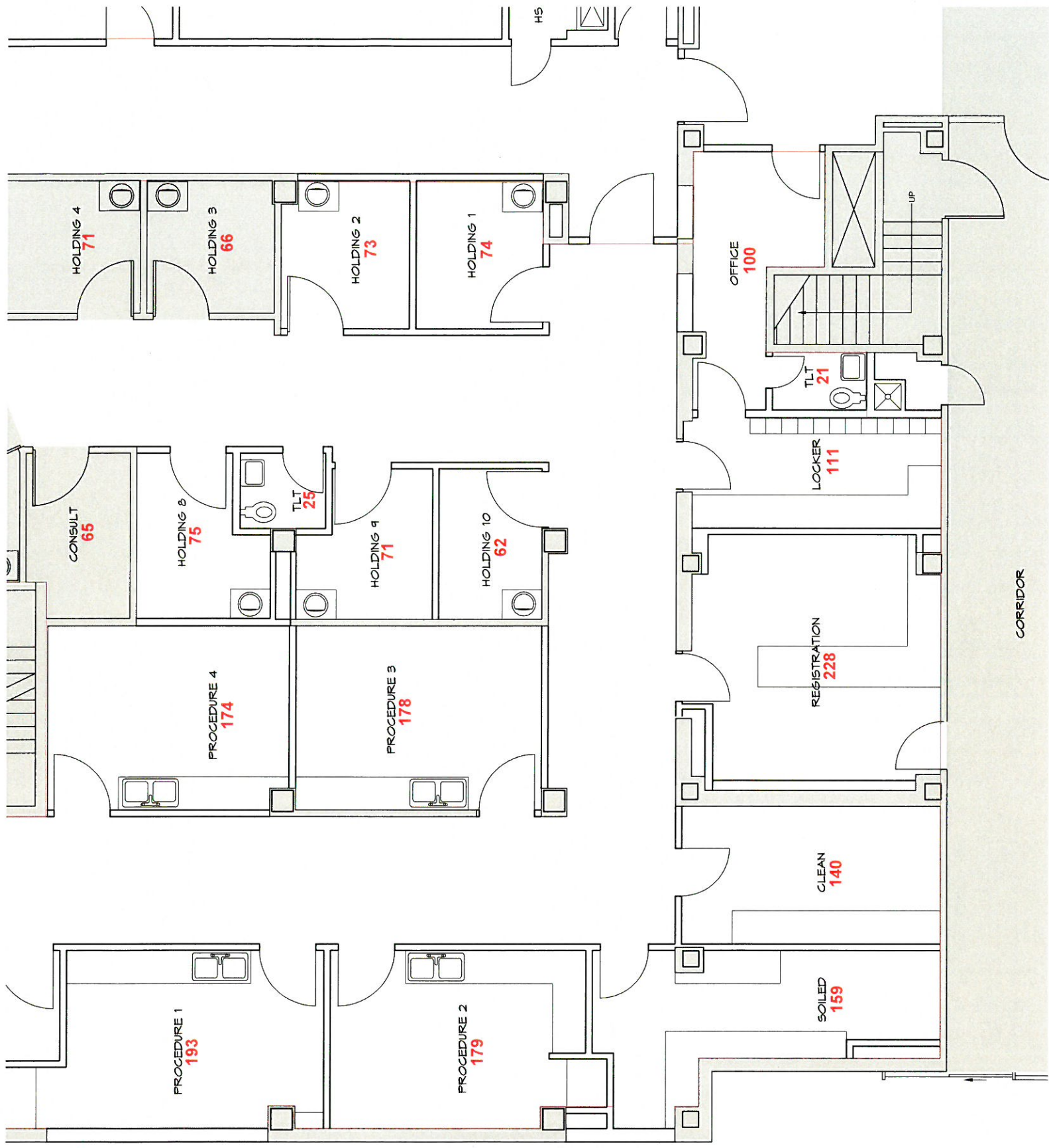

1ST FLOOR

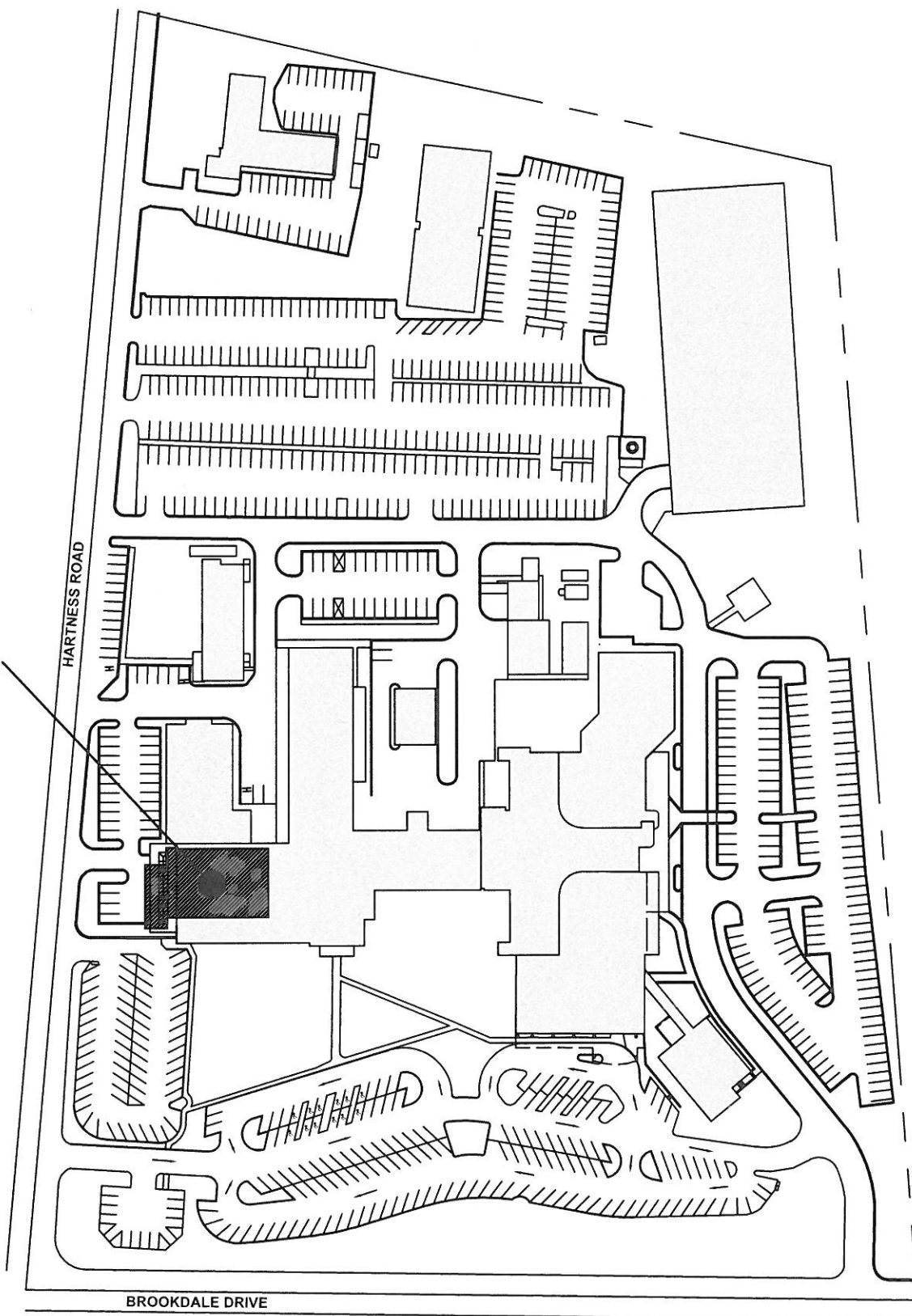

HARTNESS ROAD

BROOKDALE DRIVE

